

Design and Performance improvement of Downstream RoF PON OFDM system

ShivaniRaval

Assistant Professor, Electronics and communication Department
SRPEC,Unjha,Mehsana
ravalshivani057@gmail.com

Abstract - Radio over Fibre (RoF) is developing technology in terms of security, reliability and coverage. RoF is efficient is to enhance the capacity and bandwidth for radio signals over long distance. The use of OFDM with Radio over Fiber system is used to increase modulation technique and reduce various phase modulation, electrical power attenuation and chromatic dispersion. But the limitation is to use at higher distance. In this paper we design single Rof PON OFDM link at 10Gbps using QAM technique. For increasing distance DCF technique is used and also we also measure the performance of the system at long distance with and without DCF technique. Further the effectiveness of DCF is also checked by increasing channel upto 4 using WDM technique.

IndexTerms– OFDM(Orthogonal Frequency division multiplexing),PON(Passive Optical Network),QAM(Quadrature amplitude Multiplexing),WDM(Wavelength division Multiplexing),RAU(Remote antenna unit)

I. Introduction

As the increase in demand for multimedia service and wireless high-speed data, the large bandwidths in millimetre-wave having frequency (25 – 100 GHz) is considered for broadband wireless applications to solve the problem of spectral congestion. The full bandwidth is used to transfer high quantity voice speed data. The size of Pico cells is reduced due to loss occur in the atmosphere. Also, the base station requirement is increased[4]. In such situation Radio-over-Fibre technology proves to be vital and make effective use of optical fibre links to distribute RF signals from a central station to base stations (BSs)[3].

Orthogonal Frequency Division Multiplexing (OFDM) is used to overcome the problem of multipath fading. It is a cost-effective and flexible with RoF technique. However, low frequency electronics at the CS, increased cell capacity allocation, single laser source provide control to remote antenna and also able to protect energy loss at frequency domain. RoF distribution antenna systems based on OFDM can be smoothly compatible with broadband access optical networks like WDM-PON. QAM is used with OFDM at transmitter and receiver side because its spectral efficiency is higher than other modulation technique. There are many advantages of Wavelength Division Multiplexing in RoF Network. Out of one is giving different wavelength to each Base station by simplifying network topology. It becomes difficult for destination users to get high data rates due to access bottleneck

the solution is to build up in optics the point-to-multipoint topology i.e. PON. From one channel number of users can be operated i.e. 1:2, 1:4 etc. It avoids costly optic-electronic conversions, minimum amount of feeder fiber, optical transceivers, and the cost of transceiver is divided by N customers, can be installed anywhere and no power needed. It can operate at 10Gbps. In this we have operated 4x1 WDM systems at 65536 sequence length. The system works efficiently till 100km but at longer distance i.e. 120 km and more DCF technique is implemented.

The entire document should be in Times New Roman or Times font. Type 3 fonts must not be used. Other font types may be used if needed for special purposes.

WORKING OF RoF AND ITS COMBINATION WITH QAM OFDM TECHNIQUE

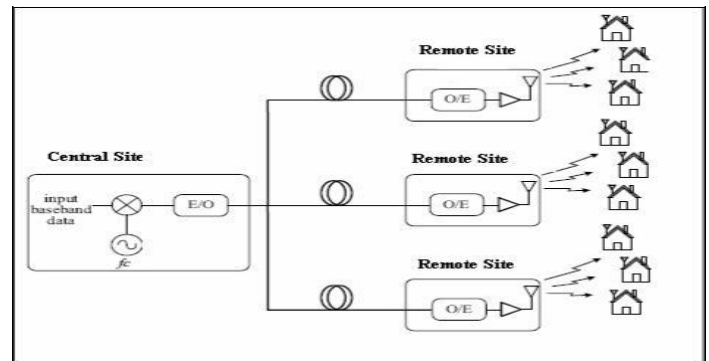

Fig 1: Basic Rof System [1]

A RoF system consists of Central site (CS) and Remote site (RS) both are connected by an optical fibre network as shown in Figure 1. RF signal processing performs functions such as carrier modulation, frequency up-conversion and multiplexing which take place at the Central Station. This will reduce installation and maintenance cost at Base station and simplifies base station.

As the base station complexity is reduced single high capacity CS can handle multiple BS to avoid the problem such as cell edge problem or dead zone problem. The RoF system is the combination of wire and wireless where the process from CS to RS is through fiber and the process from RS to BS is wireless.

II INTERNAL STRUCTURE OF OFDM

OFDM process will split the higher data signal to lower

stream data signal and then will transmit. OFDM mechanism starts with modulation technique which includes QAM. As in our process 4QAM technique is used it will generate 4 points at input side. After modulation IFFT take place where conversion from frequency domain to time domain take place. Before digital to analog convertor parallel to series conversion is done. While on receiving side series to parallel conversion take place before FFT. FFT modulation provide orthogonality which prevents demodulator from seeing frequency other than own and convert time to frequency domain. Thus OFDM is used to reduce multipath effect and maintain orthogonality.

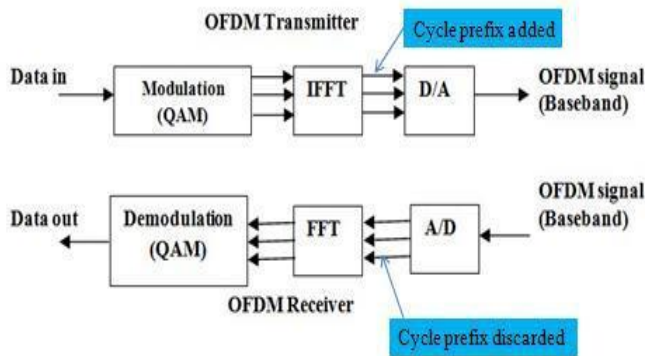

Fig 2: Block diagram of OFDM [2]

III. EXPERIMENTAL SETUP

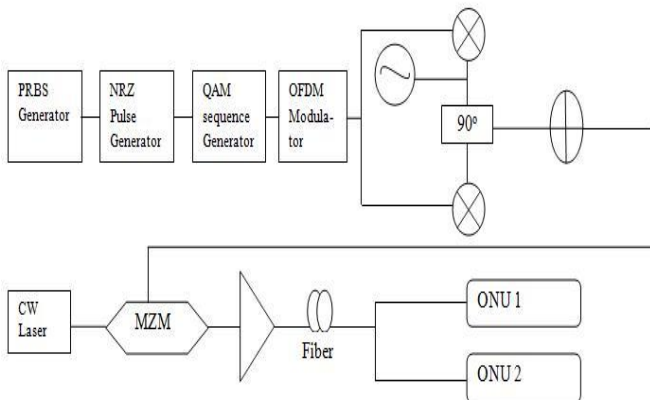

Fig 3: Experimental setup 10 Gbps single channel RoF OFDM PON System

Fig 3 shows the experimental setup for 10 Gbps RoF OFDM system which provide signal to two users using PON system. The PRBS generator consists of sequence length of 2^{16} . Output of OFDM is applied to adder which is the combination of sine and cosine function. Such combination is needed to provide 90° shift and the system is RoF, the frequency is set to 7.5 GHz. The optical signal from CW laser whose frequency centered at 193.1 THz multiplexed through MZM modulator by maintaining power level of each channel is -2 dBm. 100 GHz spaced apart multiplexed signal applied to fiber. After converting to optical, the signal is applied to two ONU systems; contain OFDM receiver and detector part. For single

channel the system goes through 300 km with 4 user using DCF technique.

When the SMF length is increased to 140 km the power is reduced from -60 dBm to -65 dBm as shown in figure 4. At 300 km, the power of the EDFA is increased more than 75 dB. The quality of the signal or a fiber length is not affected by EDFA, when the signal transmitted gets low power, it just amplifies signal. By varying the laser power the output receives power also varies.

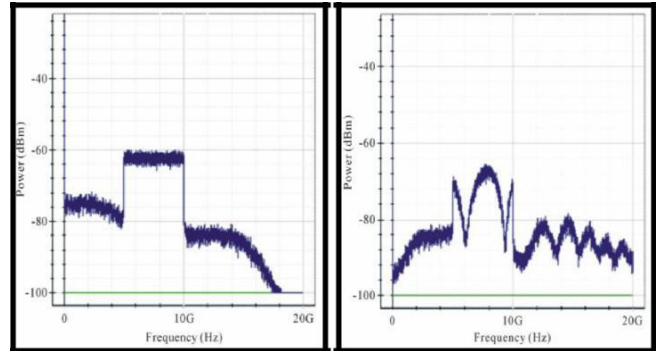

Fig 4(a) Power level at 100 km and 140 km

Table 1: Parameter of system

Parameter	Value
Number of FFT points	1024
Length	300 km (single channel) 120 km (4 channel)
Attenuation	0.2 dB/km
Dispersion	16 ps/nm/km
Dispersion slope	0.075 ps/nm ² /km
Symbol rate	2.5 symbol/sec

IV. PERFORMANCE IMPROVEMENT USING DCF

The use of dispersion compensating fiber is an effective way to upgrade the installed links made of single mode fiber. Conventional dispersion compensating fibers used to compensate the positive dispersion of transmission fiber and also have negative dispersion value between -70 to -90 ps/nm.km. DCF should have large chromatic dispersion coefficient to minimize the size of a DCF module. High chromatic dispersion coefficient gives large bending loss.

$$D_{SMF} \times L_{SMF} = -D_{DCF} \times L_{DCF}$$

By placing one DCF cable of suitable length according to the above formula into SMF, the impact of unwanted dispersion can be mitigated to approximately zero level.

- (i) Pre Compensation
- (ii) Post Compensation
- (iii) Mix Compensation

The operating system works on mix compensation technique which is explain below

Mix-Compensation

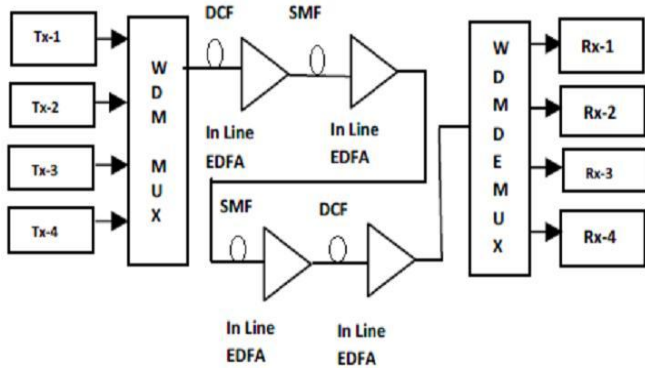

Fig 5: Mix compensation technique

Mix compensation is combination of pre and post compensation scheme. Mix compensation technique gives better stimulation result as compared to other two techniques. The process of mix-compensation is shown in figure 5. Amplifiers are introduced at every short distance of fiber which reduced the dispersion at every short distance. Thus the overall dispersion of fiber is reduced as compared to the system without DCF. Mix compensation technique is used same way for single and 4 channels

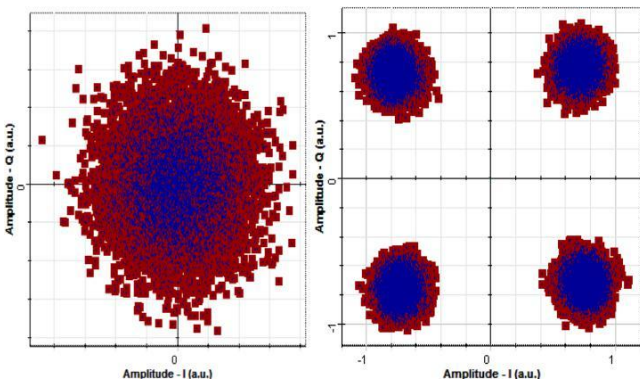

Fig 6 Constellation diagram (a)without DCF at 120km (b)with DCF 120km

Fig 6shows the effectiveness of DCF technique with help of constellation diagram. For single channel if the length of fiber is increased the dispersion is introduced in the fiber. Thus, for the longer fiber length DCF technique is used in which pre and postsboth compensation techniques are combined. Fig(b)shows the constellation with DCF technique. We can even see that constellation points are situated within range of [1,-1] which is preferable

V.RESULT AND DISCUSSION

Fig 7 shows the constellation diagram of 4x1 WDM channels at 120km. DCF is used at fiber for long reach and the constellation is improved as compared to without DCF. The constellation points are more scattered as compared to single channels as the system works on 65526 sequence length and 4 channels are combined

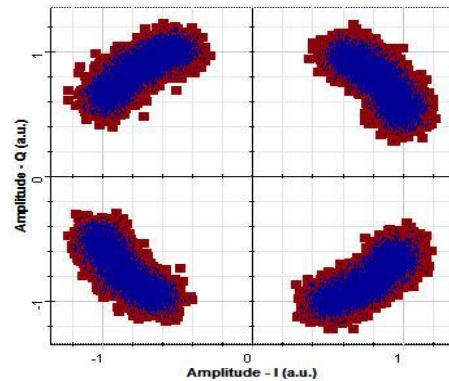

Fig 7: Constellation at receiver side for 4x1 channel

For analyzing the effect of DCF (Dispersion compensation fiber) on system we simulate the system by taking 4 channels which is multiplexed by WDM. Simulation carried out for different distance by measuring Signal to Noise ratio(SNR) and Noise figure (NF) with DCF and without DCF at receiver side in dB. From that we plot the graph of SNR and NF v/s Distance as shown in Fig 8. SNR value is decreasing as distance increasing due to linear and nonlinear impairments. But, value of SNR with DCF is higher as compared to value of SNR without DCF as shown in Fig 8(a) because of DCF technique which consist of amplifier at every half distance and make system to operate long distance with better performance. Fig (b) shows the NF versus distance . NF for any system should be low and with increase in distance it get increased. From stimulated result it can be observed that NF with DCF is low as compared to NF without DCF.

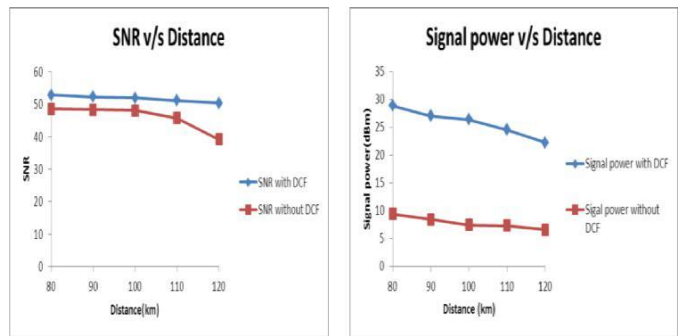

Fig 8: Graph plot of (a)SNR versus distance with and without DCF (b)NF versus distance with and without DCF

VI.CONCLUSION

From simulation resultwe demonstrated that 10 Gbps 4x1 RoF OFDM PON systemwhich goes through longer distance by reducing dispersion by DCF technique. Dispersion and

nonlinearity are limitation factor for the long haul high speed optical communication. Dispersion is compensated and performance is improved, which leads the system to go through long distance. Performance of system enhanced through the DCF which we experimentally verified. The system can further be used for more number of channels.

VII. REFERENCES

- [1] Norazan Mohd Kassim, "Recent trends in Radio Over Fiber" 1st Ed. Malaysia, 2008.
- [2] R. Karthikeyan, "OFDM Signal Improvement Using Radio over Fiber for Wireless System", *International Journal of Computer Networks*, Vol. 3, No. 3, June 2013.
- [3] Diogo Coelho, Henrique M. Salgado, "OFDM Signals in WDM Radio-Over-Fiber Networks with Fiber Bragg Grating Selection", *ICTON/IEEE*, 2009.
- [4] Y. Chung, K. Choi, J. Sim, H. Yu, "60-GHz-band analog optical system-on-package transmitter for fiberradiocommunication", *J. Lightwave Technol.*, vol. 25, no. 11, Nov. 2007.
- [5] Wei Ji, Xiao Li, "Design of WDM-RoF-PON Based on Improved OFDM Mechanism and Optical Coherent Technology", *Journal Opt. Commun. Network*, *Optical Society of America*, Vol. 7, No. 2 February 2015.
- [6] Yoon-Khang Wong, S. M. Idrus, and I. A. Ghani, "Performance Analysis of the OFDM Scheme for Wireless over Fiber Communication Link", *International Journal of Computer Theory and Engineering*, Vol. 4, No. 5, October 2012.
- [7] Nimish Kumar Srivastava, "Design and Performance Analysis of Radio over Fiber System Incorporating Differential Phase Shift Keying Modulation in High Speed Transmission System" *IOSR Journal of Electronics and Communication Engineering (IOSR-JECE)* e-ISSN: 2278-2834, p-ISSN: 2278-8735. Volume 9, Issue 2, PP 37-42, Ver. IV (Mar - Apr. 2014).
- [8] Gurprakash Singh and Arokiaswami Alphones School of Electrical and Electronic Engineering Nanyang Technological University, Singapore, "OFDM Modulation Study for a Radio-over-Fiber System for Wireless LAN (IEEE 802.11a)", *IEEE*, 2013.
- [9] Abraham Hailay, Fabio Bottoni, Ernesto Ciaramella, "RoF Using Optically Equalized RSOA WDM-PON Architecture", *IEEE*, 2014.
- [10] Wei Ji and Zhaoyuan Kang, "Design of WDM RoF PON Based on OFDM and Optical Heterodyne", *Journal Optical Communication*, *IEEE*, VOL. 5, NO. 6/JUNE 2013.
- [11] Vishal Sharma, Sushank Kumar, "Hybrid OFDM-OSSB-RoF transmission system incorporating fiber Bragg grating", *Optik journal*, *Science Direct*, 2013.
- [12] Naresh Kumara, Ajay K. Sharmab, Vinod Kapoor, "Enhanced performance analysis of 10Gbit/s optical OFDM-RoF transmission links", *Optik Journal*, *Science Direct*, 2014.
- [13] R. Karthikeyan, Dr. S. Prakasam, A Review "OFDM-RoF (Radio over Fiber) System for Wireless Network", *International Journal of Research in Computer and Communication Technology*, Vol 3, Issue 3, March-2014.